



THE ALL-NEW

TILTROTATOR

COTECH

**EQUIPMENT
MANUFACTURER**

TILTROTATOR

Unlock the full potential of your excavator

Designed and fully integrated by Cotech, this complete system is purpose-built for compact excavators. Featuring 360° continuous rotation, a 100° tilt angle range (50° on each side), and a cylinderless design, this compact solution delivers unmatched productivity and versatility, regardless of the application or excavator position.



360°
ROTATION

50°
TILT



Smarter work.
More angles.

NO CYLINDERS. COMPROMISES.

Dig deeper, without cylinders blocking the way.

Instead of using external tilt cylinders, the Cotech tiltrotator features a fully enclosed design that eliminates exposed components susceptible to damage or obstruction. Its sleek, compact profile reduces the overall width of the tiltrotator, allowing for narrower trenching, improved maneuverability, and easier access to deeper excavation areas.

- Greater digging depth.
- Fully enclosed compact design.
- Reduced tiltrotator width.
- Constant tilt torque, regardless of the tilt.

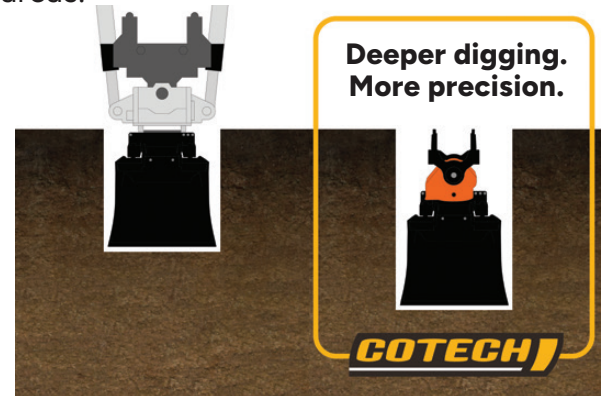

TILTROTATOR APPLICATIONS



CONFIGURE YOUR TILTROTATOR



CONTROL SYSTEM & KEY COMPONENTS



7" Touchscreen Display

- Attachment profiles.
- Colour display.
- Lock & unlock attachments.

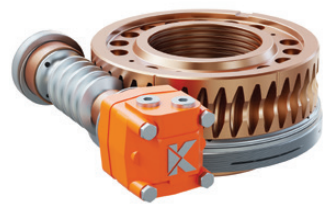

Oversized Worm Gear

- Driving the unit rotation.
- Lubricated in an oil bath.
- Low maintenance required.



Constant Holding Torque

- Helical actuator.
- Consistent holding torque across all tilt angles.



Multi-Functional Joysticks

- More controls, rollers, and improved ergonomics.

TECHNICAL SPECIFICATIONS

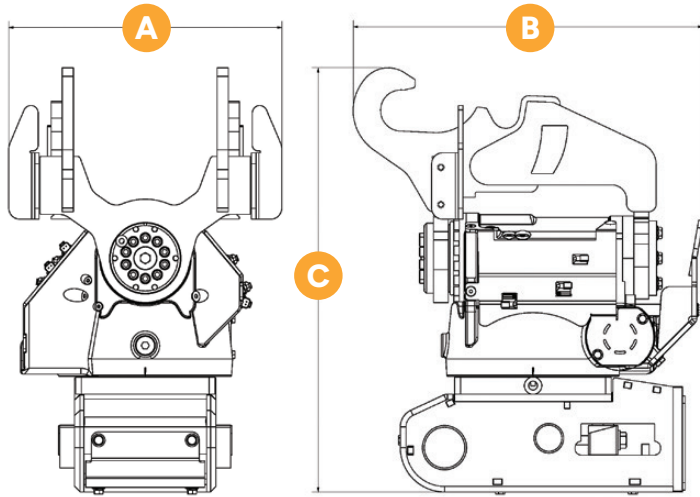

TILTROTATOR		
Specifications	TR07	TR11
Width A	19.5"	22.5"
Length B	23.7"	27.2"
Height C	28.7"	30.9"
Weight (w/o gripper)	488 lb	897 lb
Gripper	Optional	Optional
Rotational speed	8.5 lpm	8.5 lpm
Rotational torque	3,466 lb-ft	5,531 lb-ft
Tilt torque	8,113 lb-ft	11,800 lb-ft
Tilt angle	2*50°	2*50°
Excavator weight	5 to 7 tons	7 to 10 tons

OPTIONAL GRIPPER

- The hydraulic gripper adds versatility for handling materials directly with the tiltrotator.
- Compact, bolt-on design that can be easily added to your tiltrotator.
- Ideal for picking and placing rocks, concrete blocks, logs, fencing, and more.
- Can be used with or without an attachment for increased lifting capacity.





ONE SOLUTION. COMPLETE CONTROL.

- Achieve precision through tilt and rotation. Then let the attachment do the work.
- Reduces excavator repositioning and minimizes the need for additional support staff.
- Get the job done faster, all from the cab.
- A true plug & play solution fully designed, integrated, and configured by Cotech.



TILTROTATOR ATTACHMENTS



Cotech's tiltrotator is designed to handle a wide variety of standard and specialized attachments, making it a true multifunctional all-rounder.

- All Cotech attachments are compatible with the tiltrotator.
- Easily switch between buckets and other attachments without ever leaving the cab.
- More attachments, means more productivity.

Expand your excavator's capabilities with a tailored attachment lineup.

Trenching Buckets



Ditching Buckets



Asphalt Cutters



Grading Beams



Brooms



Pallet Forks



Hydraulic Pallet Forks



Construction Grapples



Multi-Purpose Grapples



Finger Grapples



**PUSHING
LIMITS**



COTECH



📍 89, Villeray Street, L'Isle-Verte

☎ 1 800 898-4440

🖱 www.cotech.ca

**EQUIPMENT
MANUFACTURER**

• **SNOW REMOVAL**

•• **EXCAVATION**

••• **AGRICULTURAL**